

GENERAL

ALIASONIC AUF60NT series is a portable transit-time ultrasonic flowmeter with clamp-on transducers for non-invasive liquid measurement of clean homogeneous fluids. Based on microprocessor and programmable flow measurement techniques the process flow can be accurately measured without interrupting the flow and with low installation costs.

FEATURES

- 4 line LCD display flowrate, totalizer & signal condition
- The flowmeter is designed in high accuracy +/-1.0%
- Small sized (200 * 92 * 32mm) and light-weight (538 g)
- Wide range, Velocities(0.01 ~ +/- 32 m/s)
- Ni-MH Battery lasts for over 10 hours continuous operation
- Transducers suitable for pipe sizes from 15 to 6000 mm
- Built-in magnet in transducers, no need for steady tool on pipe
- Data logger which records flowrate, date, total flow,signal condition... etc
- Response time less than 1 second

STANDARD SPECIFICATION

- | | | | |
|-----------------------|---|-----------------------|--|
| ● Measuring Principle | : Transit time difference | ● Keypad | : 18 Key with tactile action |
| ● Pipe Size | : SS Type : 15 mm ~ 100 mm (1/2" ~ 4")
: MS Type : 50 mm ~ 700 mm (2" ~ 28")
: M Type : 50 mm ~ 700 mm (2" ~ 28")
: L Type : 300 mm ~ 6000 mm (12" ~ 240") | ● Response Time | : Less than 1 second |
| ● Pipe Material | : Cast Iron, Stainless Steel, Ductile Iron
Copper, PVC, Aluminum, Asbestos
Fiberglass... etc | ● Flow Velocity | : 0.01 ~ +/- 32 m/s |
| ● Liner Material | : Tar Epoxy, Rubber, Mortar, Polypropylene,
Polystyrol, Polystyrene, Polyester, Ebonite,
Polyethylene, Teflon... etc | ● Resolution | : 0.0001 m/s |
| ● Display | : 4 Line LCD with illumination
Flowrate : 5 digit with decimal point
Totalizer : 8 digit, Forward, Reverse & Net values
Engineer Unit : M3, Liter, US Gallon, Imperial Gallon,
Million Gallon, Cubic Feet, US Barrels,
Imperial Barrels, Oil Barrel
Time Unit : Second, Minute, Hour, Day
Other : Velocity, Date, Time, Signal condition | ● Ambient Temperature | : -20 ~ +50 °C |
| ● Accuracy | : +/- 1% ~ +/- 2% of reading (0.5 ~ 30 m/s)
: +/- 0.5% of reading (Online calibration) | ● Ambient Humidity | : 90% RH or Less |
| ● Repeatability | : +/-0.2% of reading | ● Built-in Battery | : Ni-MH Battery |
| | | ● Operation Time | : > 10 Hours |
| | | ● Charger | : 90 ~ 260Vac 50/60 Hz, 8-12 Hr charging |
| | | ● Data Storage | : Operation parameters and totalizer
figures are stored by EEPROM for more
than 10 years |
| | | ● Data Logger | : Limitless overwriting in 64 columns
(Flowrate, totalizer, time, date included) |
| | | ● Alarm | : High/Low with buzzer |
| | | ● Power Consumption | : Less than 2W |
| | | ● Dimensions | : 200 * 92 * 32 mm |
| | | ● Weight | : 0.54 Kg |
| | | ● Protection Class | |
| | | Converter | : IP65 |
| | | Sensor | : IP68 (Submersible) |



SENSOR SPECIFICATION

- Fluid Temperature : -20 ~ +110 °C
- SS Type

Pipe Size : 15 ~ 100 mm(1/2" ~ 4")
 Dimensions : 200 * 25 * 22 mm

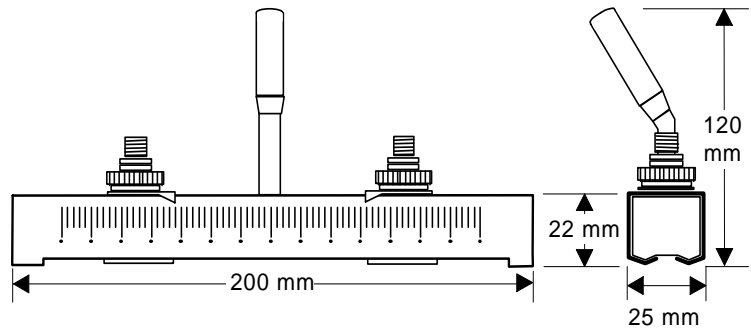

- MS Type

Pipe Size : 50 ~ 700 mm(2" ~ 28")
 Dimensions : 280 * 40 * 37 mm

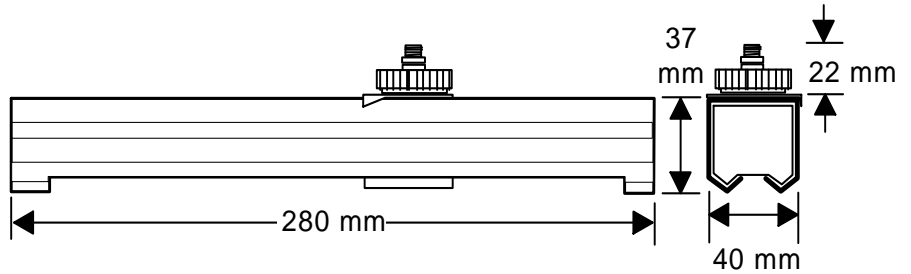

- M Type

Pipe Size : 50 ~ 700 mm(2" ~ 28")
 Dimensions : 72 * 37 * 40 mm

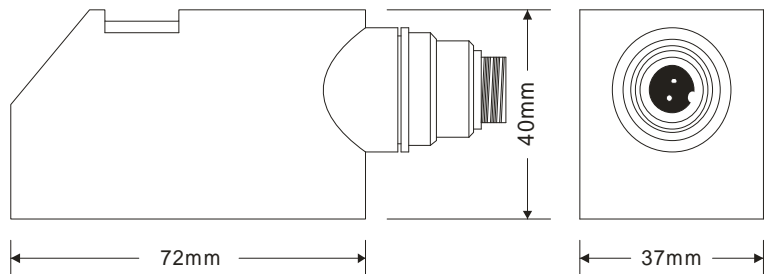

- L Type

Pipe Size : 300 ~ 6000 mm(12" ~ 240")
 Dimensions : 91 * 52 * 44 mm

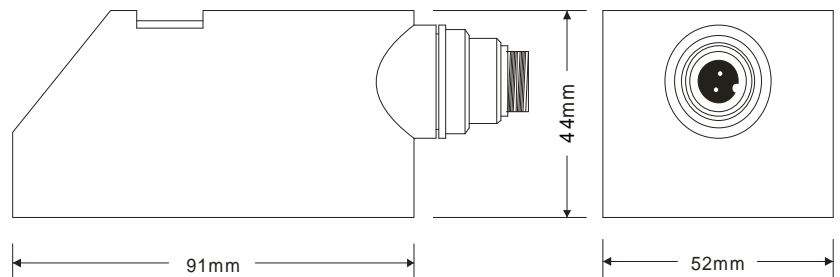

COMBINATION FOR ULTRASONIC FLOWMETER

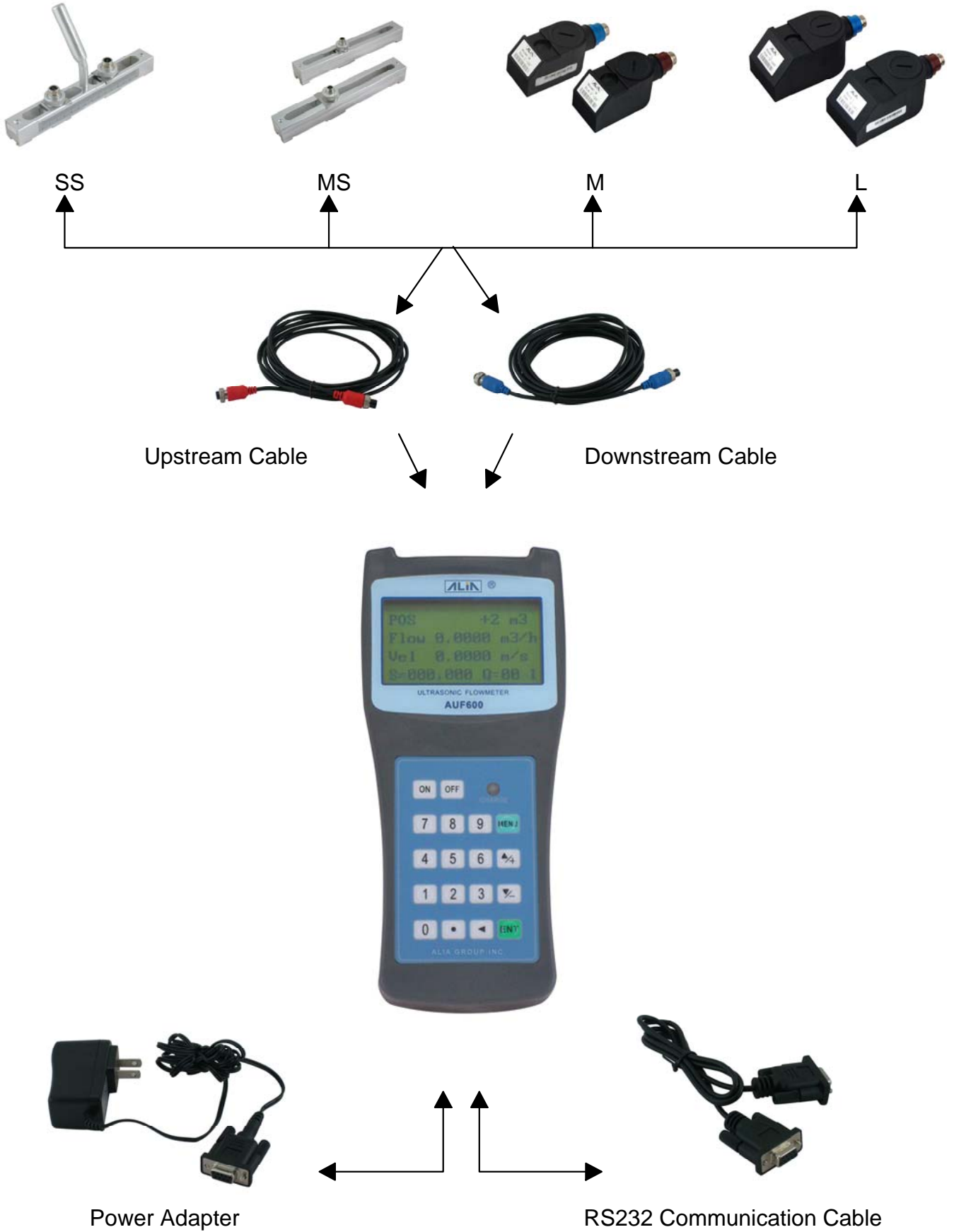

ACCESSORIES



Measuring Tape



Silicone Grease



Aluminum Carrying Case (Dimension: 470 * 380 * 110 mm)

MODEL SELECTION GUIDE

AUF60NT Series			
Example 1: AUF60NT-MS-05		Example 2: AUF60NT-SS,MS-05,10	
AUF60NT-	XX	-XX	Description
Basic Selection	AUF60NT-		Basic Model, Include * AUF60NT Converter * Power Adapter (90-265 Vac, 50/60Hz) * RS232 Communication Cable * Acoustic Gel * Aluminum Carrying Case
Detector		SS	Small Sensors with Support Tool, 15 ~ 100 mm (1/2" ~ 4")
		MS	Middle Sensors with Support Tool, 50 ~ 700 mm (2" ~ 28")
		M	Middle Sensors, 50 ~ 700 mm (2" ~ 28")
		L	Large Sensors, 300 ~ 6000 mm (12" ~ 240")
Cable Length		- 05	5M, 2 Cables
		- 10	10M, 2 Cables
		- 15	15M, 2 Cables